

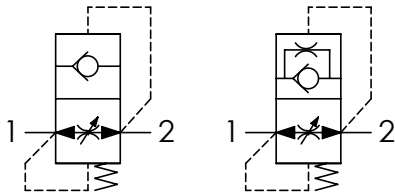

Schema idraulico - Hydraulic circuit



Con foro (With orifice)

Codice ordinazione
Ordering code

01	02	03	04
VUBA			

01	Valvole di sicurezza per tubazioni (Hose burst valves)	VUBA
02	Dimensione (Size)	BSPP 1/4 140
		BSPP 3/8 380
		BSPP 1/2 120
		BSPP 3/4 340
		BSPP 1 100
03	Regolazione (Setting)	Esempio: regolazione 0,7 mm (Example: setting 0.7 mm) F 0,7
		Omettere se non richiesto (Omit if not required)
04	Foro sul piattello (Orifice on flat poppet)	Esempio: foro 1,5 mm (Example: hole 1,5 mm) P 1,5
		Omettere se non richiesto (Omit if not required)

Regolazione F a richiesta
F setting on request

Foro su piattello a richiesta
Orifice on flat poppet on request

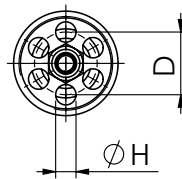
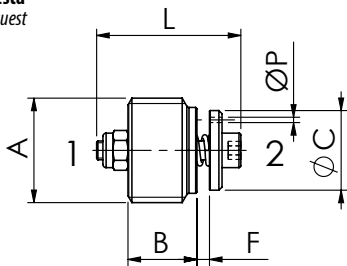

Cavità (Cavity)

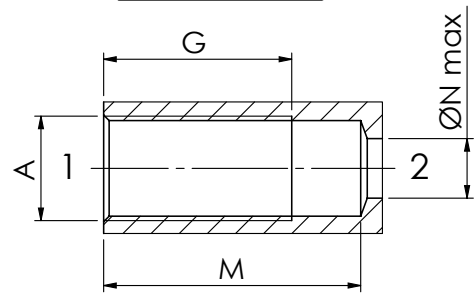

Dati tecnici - Technical data

Olio idraulico/Mineral oil	ISO 6743/4 (DIN 51524)	
Viscosità olio/Oil viscosity	15-250 mm ² /s (15 to 250 cSt)	
Classe di contaminazione max con filtro Max contamination index with filter	ISO 4406:1999 Classe 19/17/14	
Temperatura dell'olio/Oil temperature	-20°C +80°C	-4°F + 176°F
Temperatura ambiente/Ambient temperature	-20°C +50°C	-4°F + 122°F
È indispensabile l'utilizzo di un filtro per proteggere la valvola (filtrazione consigliata 15 µm) It is necessary a filter use to protect the valve (advised filtration 15 µm)		
Trafilamento massimo Max leakage	0,25 cm ³ /min - 5 gocce/min	0,015 in ³ /min - 5 drops/min

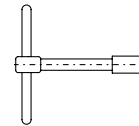

Chiave - Tool

Dimensione/Dimensions

Tipo chiave Tool's Type	Tipo Type	Peso/Weight kg/lb
61700001	VUBA140	0,12 (0.27)
61700002	VUBA380	0,13 (0.29)
61700003	VUBA120	0,15 (0.33)
61700004	VUBA340	0,18 (0.40)

Caratteristiche tecniche - Technical characteristics

Tipo Type	A	Portata max Max flow l/min-USgpm	Pressione max Max pressure bar/PSI	B	C	D	G	H	L	M	N	Coppia di serraggio Tightening torque Nm/lbt ft	Peso approssimativo Approx weight kg/lb
VUBA140	BSPP 1/4	25 (6.6)	350 (5075)	8,2 (0.32)	10,4 (0.41)	8 (0.31)	25 (0.98)	2,5 (0.10)	19 (0.75)	35 (1.38)	7 (0.28)	2 (1.5)	0,008 (0.017)
VUBA380	BSPP 3/8	50 (13.2)		11 (0.43)	12,7 (0.50)	10 (0.39)	30 (1.18)	3,25 (0.13)	23 (0.90)	41 (1.61)	9,5 (0.37)	3 (2.5)	0,014 (0.030)
VUBA120	BSPP 1/2	80 (21.1)		13 (0.51)	15 (0.59)	11,5 (0.45)	33 (1.30)	4 (0.16)	29 (1.14)	46 (1.81)	12 (0.47)	4 (3)	0,025 (0.055)
VUBA340	BSPP 3/4	150 (39.6)		18 (0.71)	18 (0.71)	14,5 (0.57)	42 (1.65)	5,2 (0.20)	34 (1.34)	55 (2.17)	16 (0.63)	10 (7.5)	0,054 (0.12)
VUBA100	BSPP 1	180 (47.5)		20 (0.79)	26 (1.02)	19 (0.75)	48 (1.89)	7 (0.28)	40 (1.57)	63 (2.48)	22 (0.87)	12 (9)	0,1 (0.22)

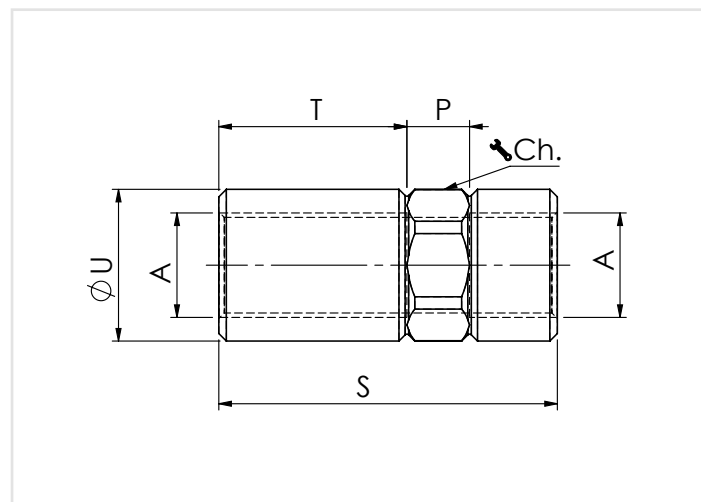
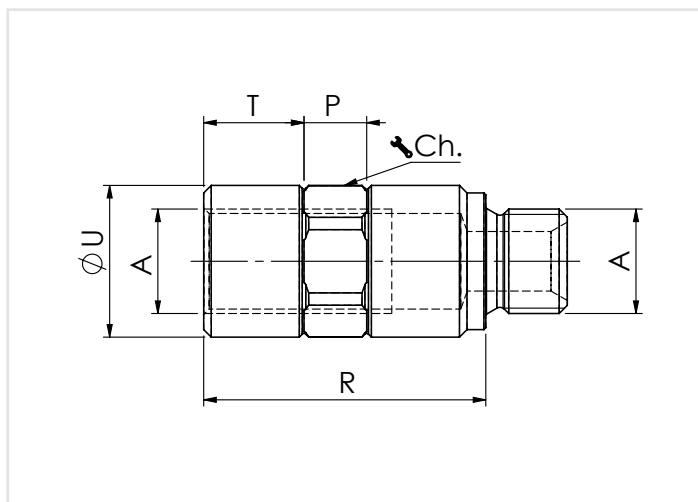

Colonnette - Housings M/F

Tipo Type	A	R	P	T	U	Ch.	Peso approssimativo Approx weight kg/lb
61100087	BSPP 1/4	39 (1.53)	10 (0.39)	13 (0.51)	20.5 (0.80)	19	0.07 (0.16)
61100088	BSPP 3/8	45 (1.77)	10 (0.39)	16 (0.63)	24.5 (0.96)	22	0.10 (0.22)
61100089	BSPP 1/2	52 (2.05)	10 (0.39)	19 (0.75)	29.5 (1.16)	27	0.17 (0.37)
61100090	BSPP 3/4	61 (2.40)	12 (0.47)	23 (0.90)	35.5 (1.32)	32	0.26 (0.57)
61100091	BSPP 1	67 (2.63)	15 (0.59)	25.5 (1)	44.5 (1.75)	41	0.4 (0.88)

Colonnette - Housings F/F

Tipo Type	A	S	P	T	U	Ch.	Peso approssimativo Approx weight kg/lb
61100092	BSPP 1/4	48 (1.89)	10 (0.39)	13 (0.51)	20.5 (0.80)	19	0.09 (0.20)
61100093	BSPP 3/8	54 (2.13)	10 (0.39)	30 (1.18)	24.2 (0.95)	22	0.11 (0.24)
61100094	BSPP 1/2	73 (2.87)	10 (0.39)	46.5 (1.83)	29.2 (1.14)	27	0.20 (0.44)
61100095	BSPP 3/4	74 (2.91)	12 (0.47)	44 (1.73)	35.5 (1.32)	32	0.27 (0.59)

Regolazione "F" - Setting "F"

