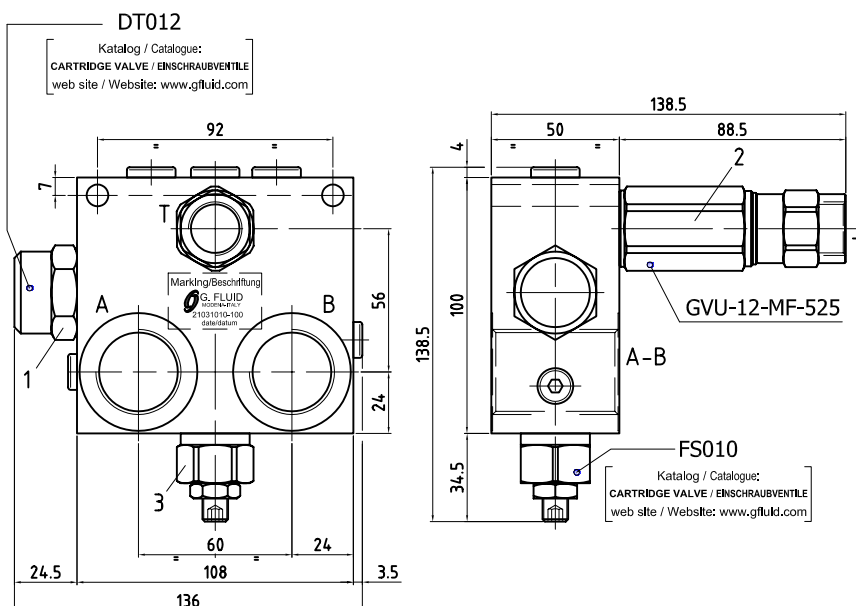
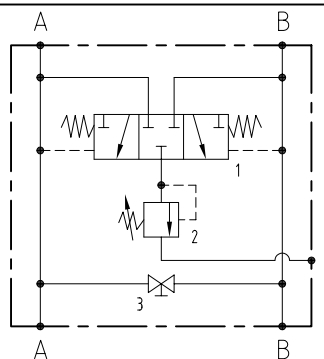

GVS-HTP-01
**TECHNICAL DATA
 TECHNISCHE ANGABEN**

Max operating pressure Maximaler Betriebsdruck	35 MPa 5076 psi
Max flow Volumenstrom	100 l/min 26.4 gpm
Temperature range Betriebstemperatur	-20°/80°C
Filtration Filtergrad	40μ
Weight Gewicht	4.2 kg
Material Material	Zincoated Steel Verzinkter Stahl

ORDERING INSTRUCTIONS - BESTELLANLEITUNG
21031010 1 0

	Port size/Gewinde A, B T		Adjustment range Regelbereich	standard setting Standardkalibrierung
4	G 3/4"	G 1/2"	0.5-2.5 MPa	1.2 MPa
5	G 1"	G 1/2"		
0				