

FLANGIA FILETTATA GAS

BSP thread flange
Brides SAE taraudées BSP
Einschraubflansch

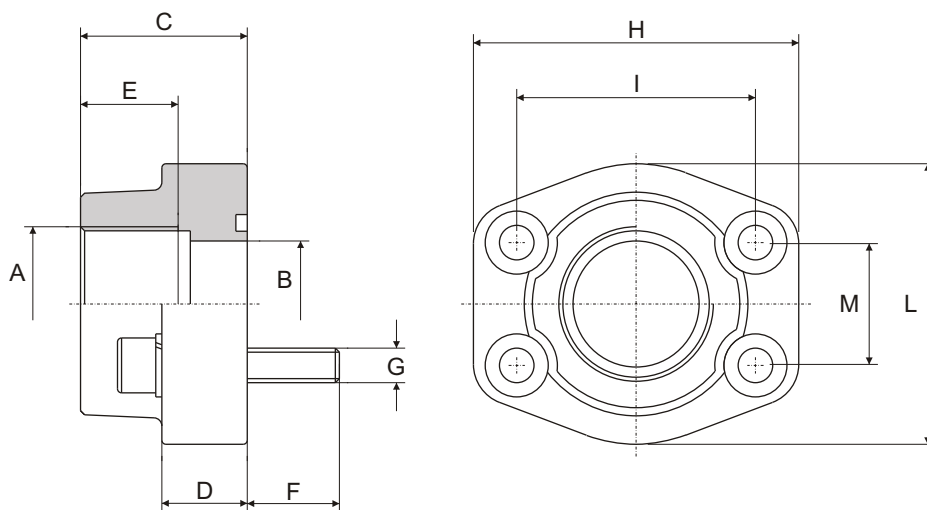

serie 3000 psi

Pressione max esercizio bar	Tipo Type	A S.A.E.	B	C	D	E	F	G Viti / Bolts		H	I	L	M	OR O-RING
								Metr.	UNC					
348	C.F.S. 080-GAS	3/8"	13	36	16	13	14	M 8	5/16"	57	38	47	17,5	4075
348	C.F.S. 080-GAS	1/2"	13	36	16	15	14	M 8	5/16"	57	38	47	17,5	4075
348	C.F.S. 100-GAS	3/4"	19	36	18	18	16	M10	3/8"	66	47,6	49	22,2	4100
348	C.F.S. 102-GAS	1"	25	38	18	20	16	M10	3/8"	71	52,4	53	26,2	4131
278	C.F.S. 104-GAS	1" 1/4	31	41	21	22	18	M10	7/16"	80	58,7	69	30,2	4150
210	C.F.S. 106-GAS	1" 1/2	38	44	25	24	18	M12	1/2"	94	69,85	77	35,7	4187
210	C.F.S. 108-GAS	2"	50	45	25	26	18	M12	1/2"	103	77,8	89	42,9	4225
175	C.F.S. 110-GAS	2" 1/2	63	50	25	30	18	M12	1/2"	115	88,9	101	50,8	4275
138	C.F.S. 112-GAS	3"	73	50	27	30	25	M16	5/8"	135	106,4	124	62	4337
35	C.F.S. 114-GAS	3" 1/2	89	50	27	30	25	M16	5/8"	152	120,7	136	70	4387
35	C.F.S. 116-GAS	4"	99	50	27	30	25	M16	5/8"	162	130	146	77,8	4437
35	C.F.S. 118-GAS	5"	120	50	28	30	25	M16	5/8"	184	152,4	180	92	4537

serie 6000 psi

Pressione max esercizio bar	Tipo Type	A S.A.E.	B	C	D	E	F	G Viti / Bolts		H	I	L	M	OR O-RING
								Metr.	UNC					
420	C.F.S. 401-GAS	3/8"	13	36	16	13	14	M 8	5/16"	57	40,5	47	18,3	4075
420	C.F.S. 401-GAS	1/2"	13	36	16	15	14	M 8	5/16"	57	40,5	47	18,3	4075
420	C.F.S. 402-GAS	3/4"	19	36	19	18	16	M10	3/8"	71	50,8	53	23,8	4100
420	C.F.S. 403-GAS	1"	25	44	24	20	19	M12	7/16"	80	57,1	69	27,8	4131
420	C.F.S. 404-GAS	1" 1/4	31	44	27	22	22	M14	1/2"	94	66,7	77	31,6	4150
420	C.F.S. 405-GAS	1" 1/2	38	51	30	24	24	M16	5/8"	106	79,4	89	36,5	4187
420	C.F.S. 406-GAS	2"	50	70	37	33	32	M20	3/4"	135	96,8	116	44,4	4225
420	C.F.S. 408-GAS	2" 1/2	63	75	45	35	40	M24	-	166	123,8	150	58,7	4275
420	C.F.S. 410-GAS	3"	73	90	55	40	55	M30	-	208	152,4	178	71,4	4337

Per ordinazione flange: / Ordering Examples: / Pour commander brides: / Bestellbeispiel für Flansche:

Solo flangia.....CFS...G Flangia completa di viti UNC, rondelle e OR.....CFS...G-U Flangia completa di viti metriche, rondelle e OR.....CFS...G-M
 Only flange.....CFS...G Complete flange with UNC screws, washers and o-ring.....CFS...G-U Complete flange with metric screws, washers and o-ring.....CFS...G-M
 Seulement bride..CFS...G Bride complete des vis UNC, rondelles et OR.....CFS...G-U Bride complete des vis métriques, rondelles et OR.....CFS...G-M
 Nur Flansch.....CFS...G Flansch einschl. UNC-Schrauben, Federringen und O-Ring..CFS...G-U Flansch einschl. metrischen Zylinderschrauben, Federringen und O-Ring..CFS...G-M