

- Cartridge design
- Sandwich plate design for use in vertical stacking assemblies
- With integrated logic valve
- Installation dimensions to ISO 4401 and DIN 24 340-A10; NFPA T3.5.1M R1 and ANSI B 93.7 D 05
- Possibility of LS-Signal through Adapter M10/G1/4-ED

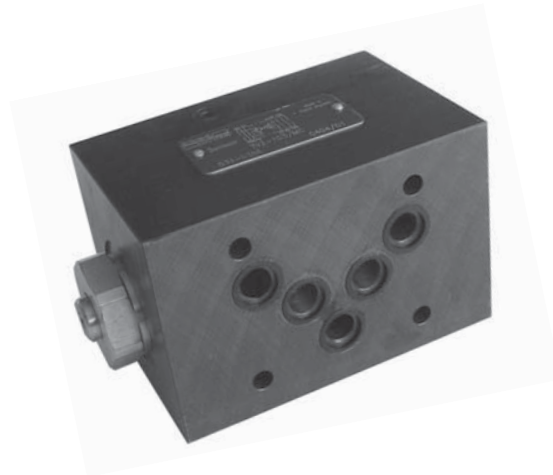
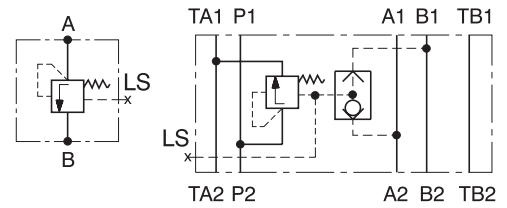

Functional Description

The valve TV2-103 is designed as a sandwich and cartridge plate. Sandwich design consist of a body (1), cartridge pressure compensator (2) with control spool (3) and logic valve in model "C" - where the ports A and B are always connected through the logic valve seat with the spring side of spool. The higher pressure pushes the ball onto the seat that is affected by lower pressure. This always causes the channel with the higher pressure to be connected with the control spool spring room (4). The required pressure difference between port P and the spring room is adjusted. When the pressure difference

between P and the spring room exceeds the value set, the control spool shifts, causing the part of pressure fluid to pass from P to T until the desired pressure difference has been restored.

Usually, this pressure compensator is used in connection with a proportional directional valve. In this case, each value of the control signal a particular constant flow rate can be assigned, this being independent of load. The valve body is phosphated, all other parts are zinc coated.

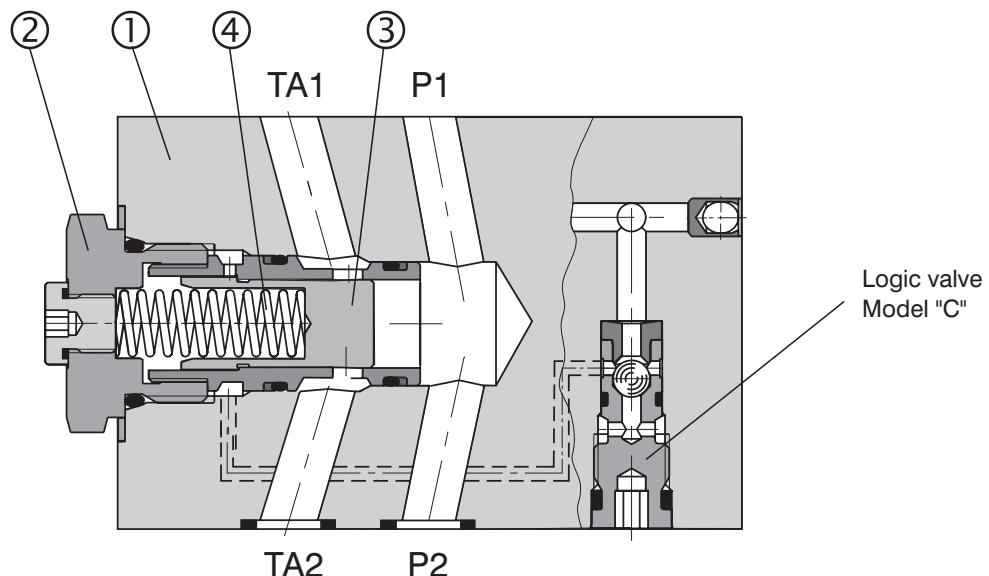

Ordering Code

TV2 - 10 3/

Pressure Compensator

Nominal size

10 (D05)

3 Way Pressure Compensator

Design

Cartridge
Sandwich plate

S
M

without designation
V

Seals

NBR
FPM (Viton)

Model

function in channel A
function in channel B
function in channels A and B

A
B
C

Technical Data

Nominal size	mm (US)	10 (D 05)
Maximum flow	L/min (GPM)	80 (21)
Max. operating pressure	bar (PSI)	320 (4600)
Pressure drop on valve Δp	bar (PSI)	10 (145)
Hydraulic fluid	Hydraulic oils of power classes (HL, HLP) to DIN 51524; (Petroleum oils (HM, HL, HLP), Phosphate ester fluids (HFD-R))	
Maximum degree of fluid contamination	Class 21/18/15 to ISO 4406 (1999).	
Weight TV2-103/MA (MB, MC) TV2-103/S	kg (lbs)	3.70 (8.2) 0.15 (0.3)
Valve tightening torque for design S	Nm (lbf.ft)	70 (51.63)
Mounting position	optional (any)	

Functional Symbols

Model S

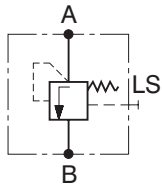

① valve side
② plate side

Model MA

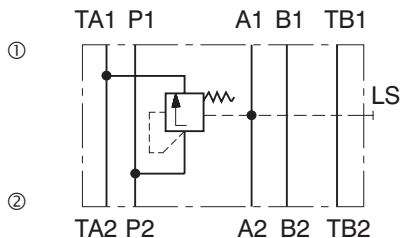

Model MB

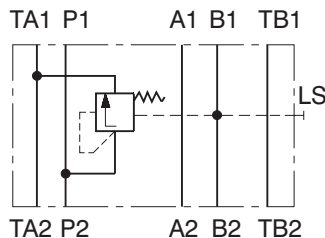

Model MC

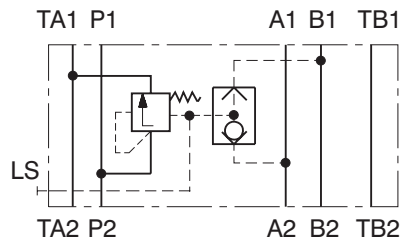

Typical Applications

TV2-103/MC

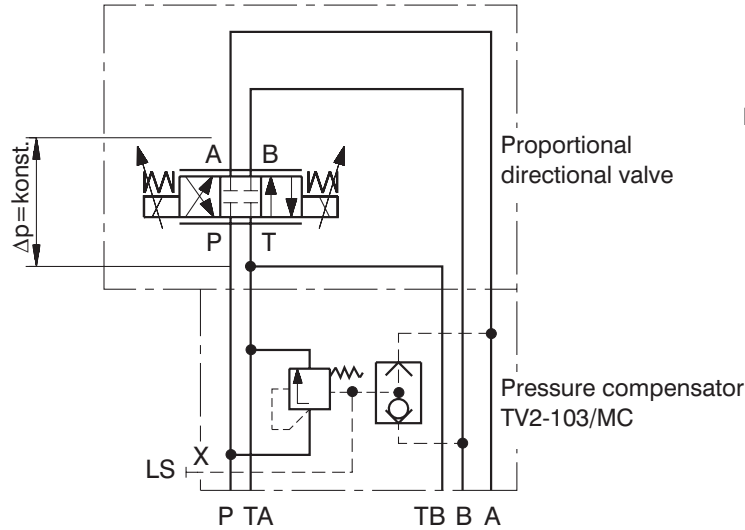

TV2-103/S

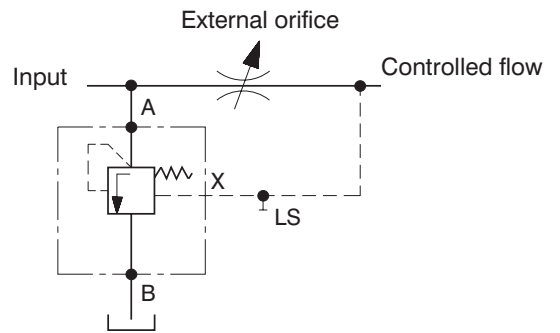

Characteristics

Measured at $v = 32 \text{ mm}^2/\text{s}$ (156 SUS)

The characteristic of the pressure compensator corresponds with the flow rate of a PRM2-103Z11/60 proportional directional valve.

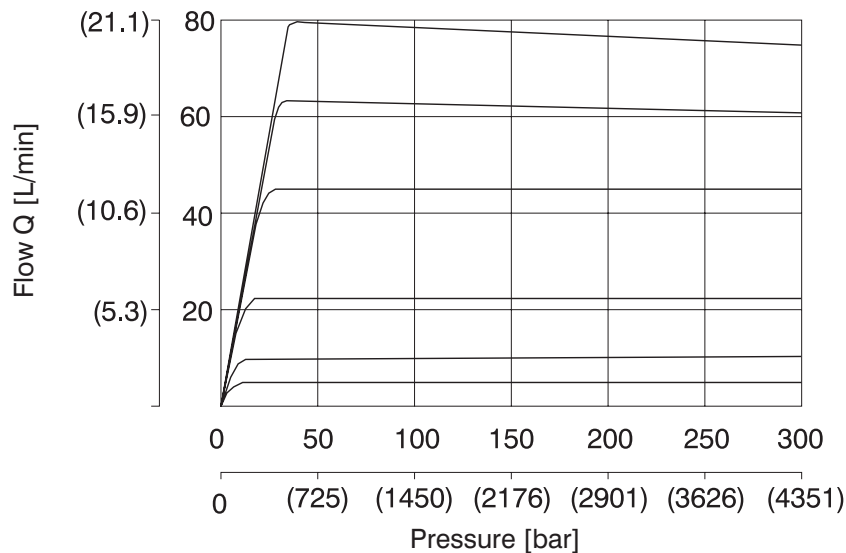

Valve Dimensions

Dimensions in millimeters (inches)

Adaptor M10/G1/4-ED

addition of equipment for LS connection
Ordering number: **19860700**

TV2-103/S

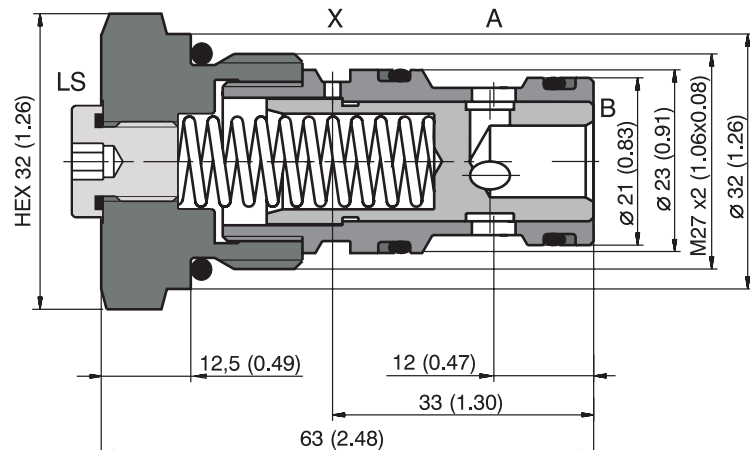
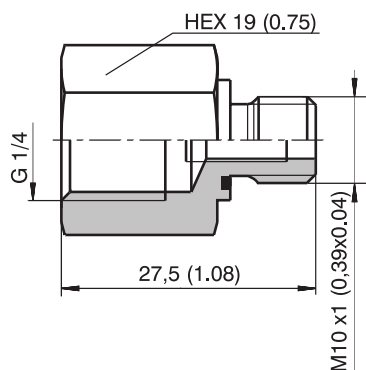

Installation cavity TV2-103

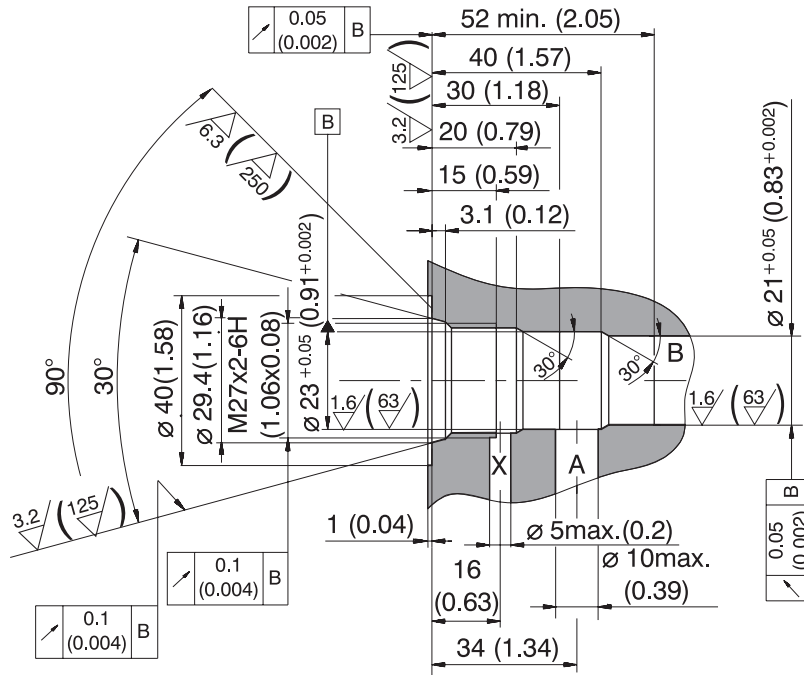

TV2-103/M

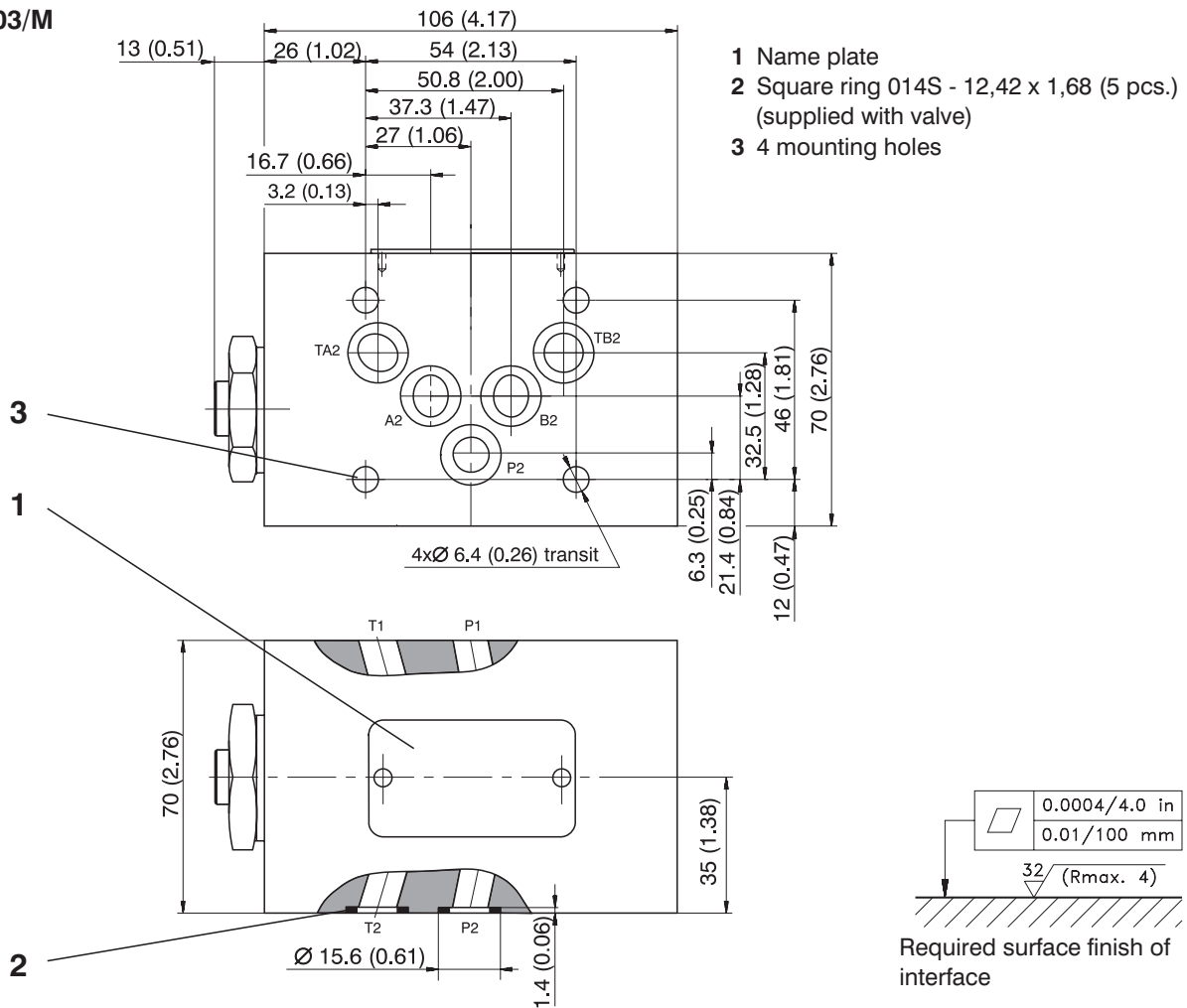

Caution!

- The packing foil is recyclable. The protective plate can be returned to manufacturer.
- The technical information regarding the product presented in this catalogue is for descriptive purposes only. It should not be construed in any case as a guaranteed representation of the product properties in the sense of the law.

ARGO-HYTOS s.r.o. CZ - 543 15 Vrchlaví
 Tel.: +420-499-403111, Fax: +420-499-403421
 E-mail: sales.cz@argo-hytos.com
 www.argo-hytos.com