

- Cartridge design
- Sandwich plate design for use in vertical stacking assemblies
- Build-in load sensing shuttle valve
- Installation dimensions to ISO 4401:1994 and DIN 24 340-A10
NFFA T3.5M R1 and ANSI B 93.7 D 05
- Possibility of LS-Signal through Adapter M10/G1/4-ED

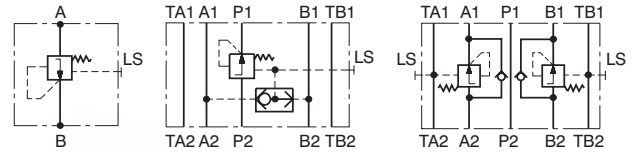

Functional Description

2 way pressure compensator for meter-in application

The 2 way pressure compensators in meter-in application will maintain a constant pressure difference across the metering edge of the proportional directional valve. In this case, the pressure variations due to load changes, as well as pump pressure changes are compensated so any increase in pump pressure does not affect the flow. The meter-in compensators may only be used with positive load direction.

Valves type TV2-102/MA,B,C are directly operated 2-way pressure compensators cartridge design in sandwich plate. They are designated for load compensation in channel P.

The main parts of these valves are the housing (1), control spool (2), spring (3) and shuttle valve (4). The spring (3) holds the spool in the open position from P2 to P1, provided that the pressure difference between P1 and A ($P1 - B$) is less than 10 bar. When the pressure difference exceeds the value of 10 bar, the spool shifts against the spring and throttled radial the housing openings until the desired pressure difference has been restored.

The pressure signal comes through passage (5) from channel A or B.

The valve body is phosphated, all other parts are zinc coated.

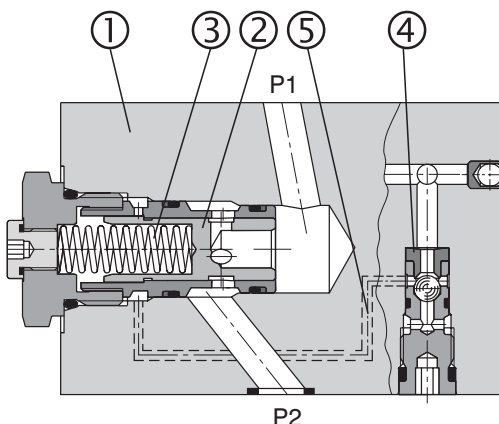

2 way pressure compensator for meter-out application

In systems with changing load directions, the use of meter-out pressure compensators is required. With respect to the application a valve with pressure compensator installed in one, or in both actuator ports are available.

The pressure compensator is always mounted between the actuator and the proportional directional valve. The valve will maintain the pressure difference between A and T or B and T constant. The flow rate and the flow direction are adjusted by the proportional directional valve. To enable the reverse flow, two by-pass check valves are incorporated into the valve body.

The valve consists of the valve body (6), one or two control spools (7) and poppets of the by-pass check valves (8). If the pump, for example, is connected to port A, the fluid passes to the actuator through a check valve and returns from the actuator through channel B to the proportional directional valve. The pressure difference across the metering edge of the directional valve is maintained at a constant level. This ensures a constant flow rate independent to the load. The pressure difference is controlled by the metering edge (9), its value being determined by spring force (10). A similar valve function develops when the proportional valve ports P and B are connected.

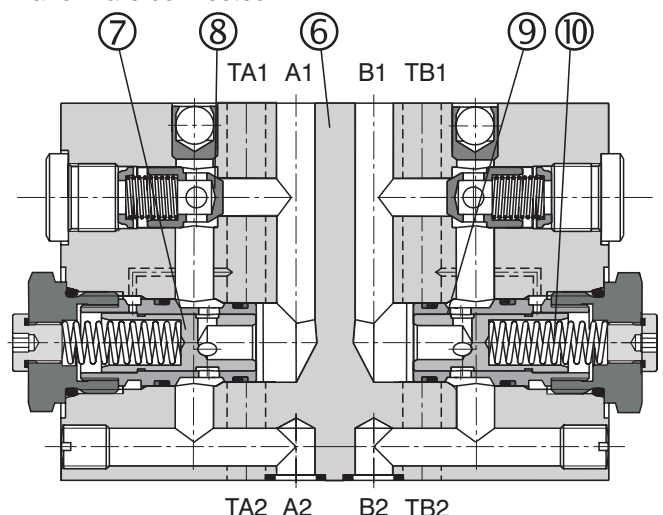

Ordering Code

	TV2 - 102/ 		
Pressure Compensator		without designation	Seals NBR FPM (Viton)
Nominal size	10 (D 05)	V	
2 Way Pressure Compensator			
Design Cartridge Sandwich plate	S M	A B C D E F	Model Meter-in compensator - function in channel A Meter-in compensator - function in channel B Meter-in compensator - function in channels A and B Meter-out compensator - function in channels A and B Meter-out compensator - function in channel A Meter-out compensator - function in channel B

Technical Data

Nominal size (Valve size)	mm (US)	10 (D 05)
Maximum flow	L/min (GPM)	80 (21)
Max. operating pressure	bar (PSI)	320 (4600)
Pressure drop on valve Δp	bar (PSI)	10 (145)
Hydraulic fluid	Hydraulic oils of power classes (HL, HLP) to DIN 51524 (Petroleum oils (HM,HL, HPL); Phosphate ester fluids (HFD-R))	
Maximum degree of fluid contamination	Class 21/18/15 to ISO 4406 (1999).	
Weight TV2-102/S		0.15 (0.3)
TV2-102/MA (MB, MC)	kg (lbs)	3.70 (8.2)
TV2-102/MD (ME, MF)		6.65 (14.7)
Valve tightening torque for design S	Nm (lbf.ft)	70 (51.63)
Mounting position		optional

Functional Symbols

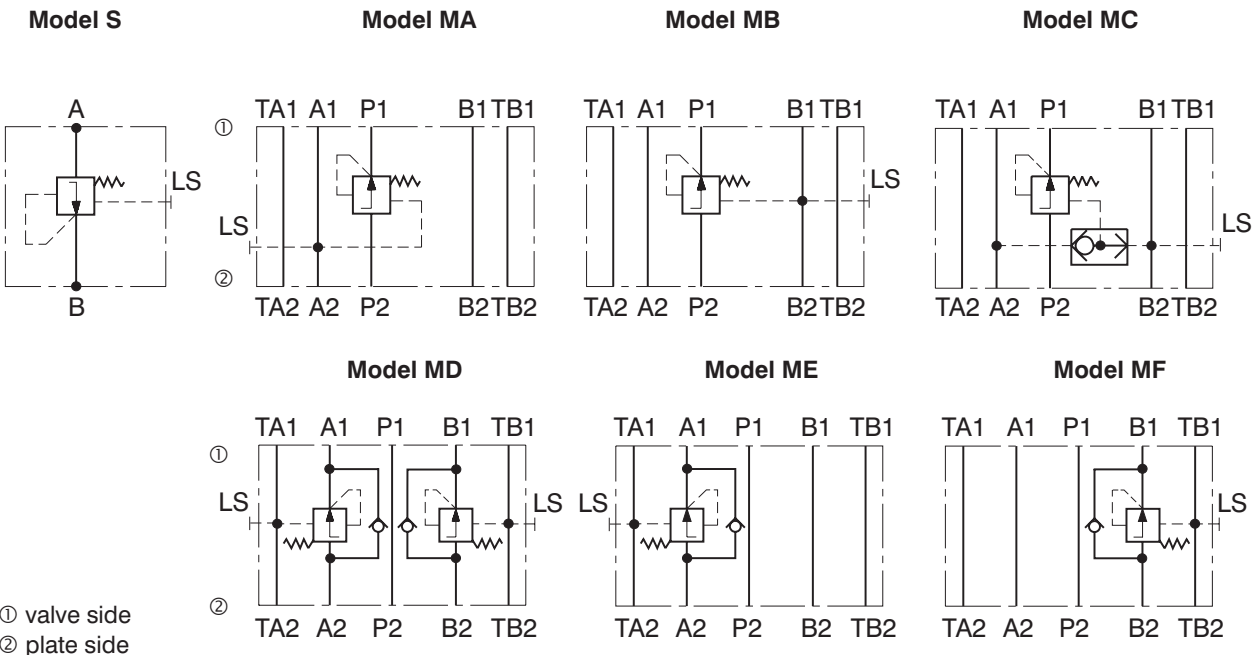

Typical Application

TV2-102/MC Meter-in compensator

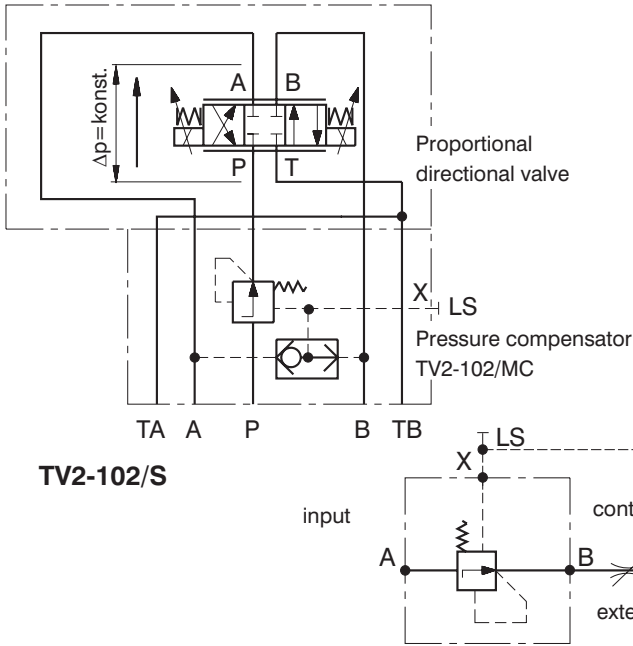

TV2-102/MD Meter-out compensator

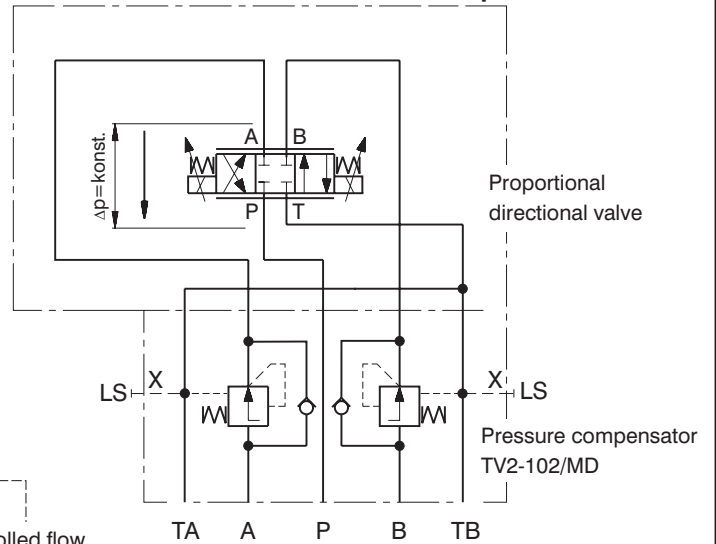

TV2-102/S

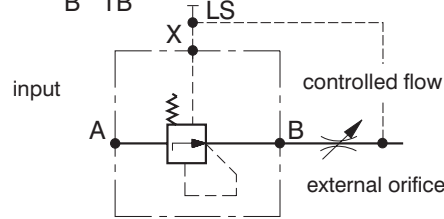

Characteristics

Measured at $v = 32 \text{ mm}^2/\text{s}$

The characteristic of the pressure compensator corresponds with the flow rate of a PRM2-103Z11/60 proportional directional valve.

TV2-102/MC Meter-in compensator

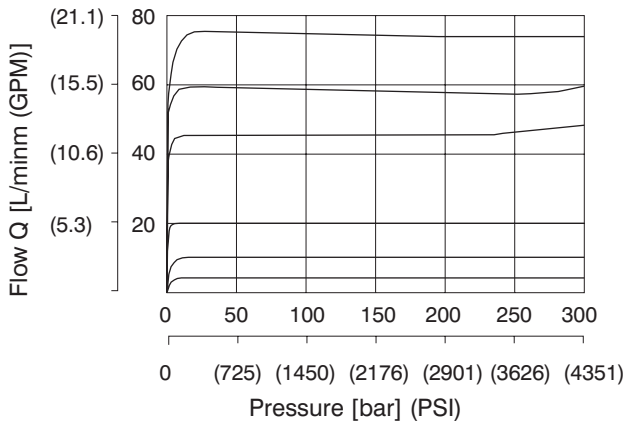

TV2-102/MD Meter-out compensator

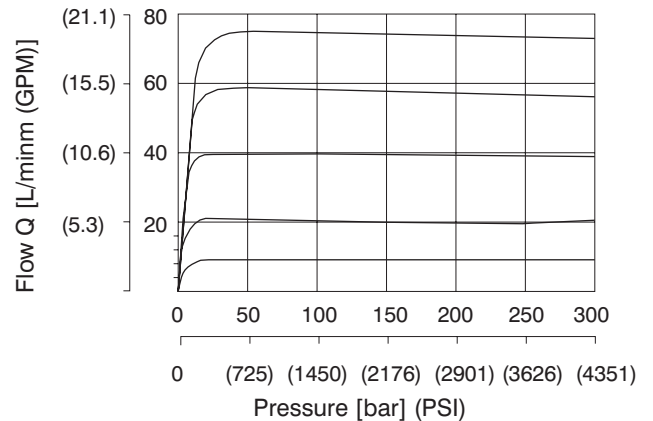

Valve Dimensions

Dimensions in millimeters (inches)

Adaptor M10/G1/4-ED

addition of equipment for LS connection
Ordering number: **19860700**

TV2-102/S

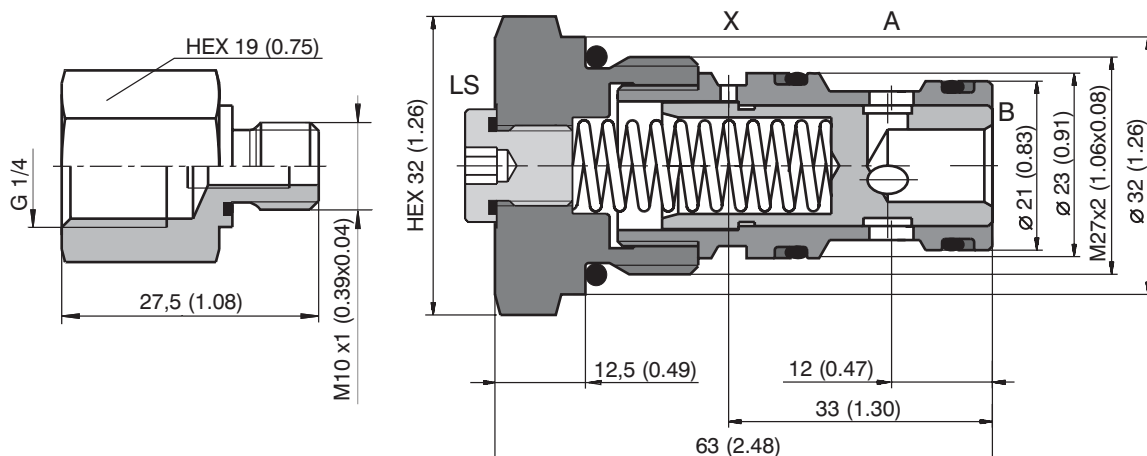

Installation cavity TV2-102

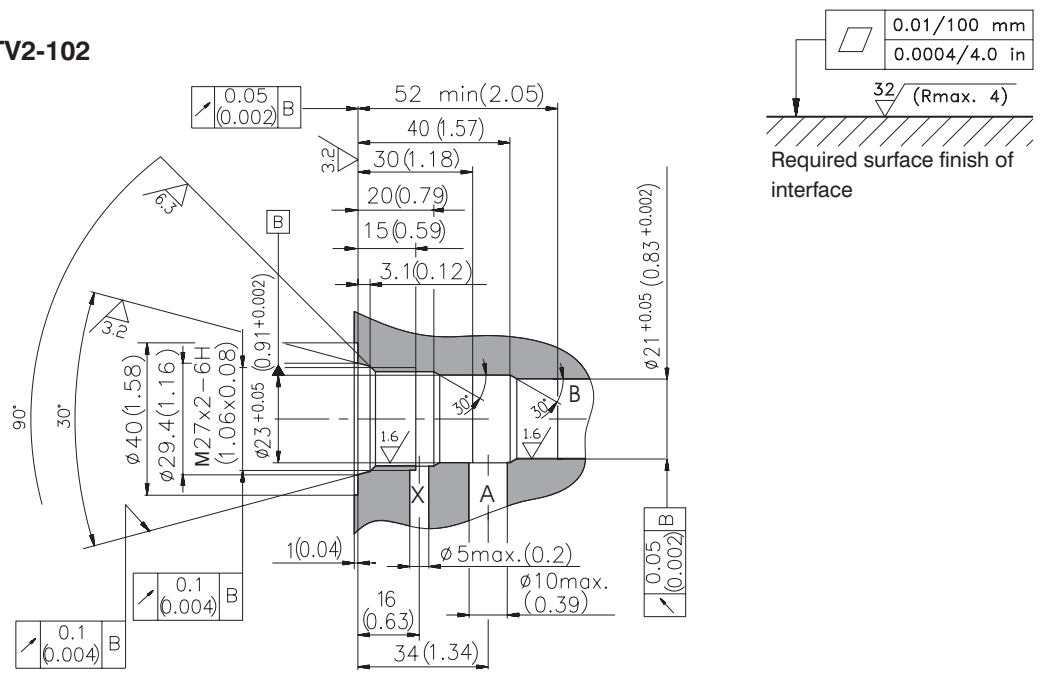

TV2-102/M Meter-in compensator

TV2-102/M Meter-out compensator

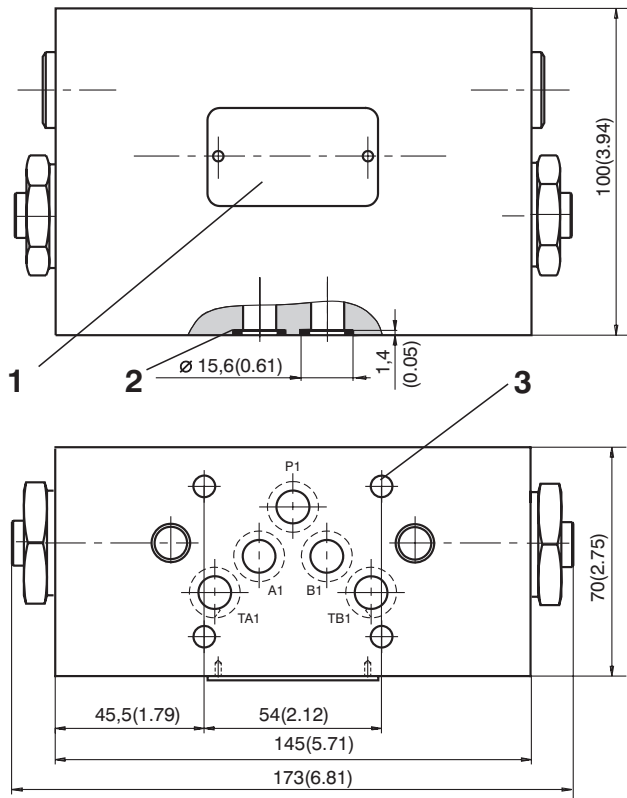
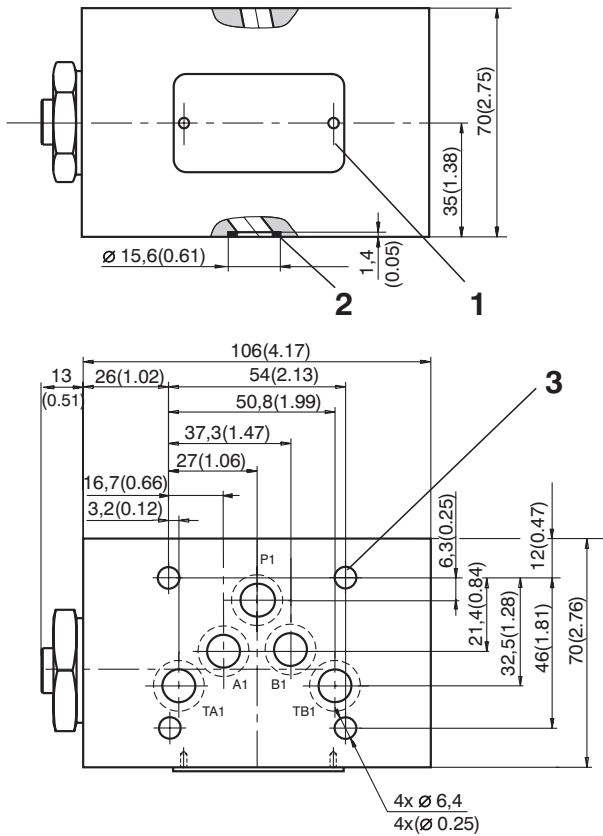

- 1 Name plate
- 2 Square Ring 014S - 12.42 x 1.68 (5 pcs.)
(supplied with valve)
- 3 4 mounting holes

Caution!

- The packing foil is recyclable. The protective plate can be returned to manufacturer.
- The technical information regarding the product presented in this catalogue is for descriptive purposes only. It should not be construed in any case as a guaranteed representation of the product properties in the sense of the law.

ARGO-HYTOS s.r.o. CZ - 543 15 Vrchlaví
 Tel.: +420-499-403111, Fax: +420-499-403421
 E-mail: sales.cz@argo-hytos.com
 www.argo-hytos.com